

Bypassing A Filter Network

When troubleshooting a TR4500, 3900, 4000, 1800 or 3500 treadmill for a NO RPM, SPD0 or SPD1 display code, it may be necessary to take the Filter Network out of the line to verify functionality.

UNPLUG THE TREADMILL FROM THE WALL OUTLET!

To bypass the Filter Network, remove the larger red and black wires that are connected to the MCB at the MTR1 and MTR2 terminals (or the A1 and A2 terminals on the older style Pulse/Sabina MCB with the rectangle and circular boards.) Set the wires off to the side.

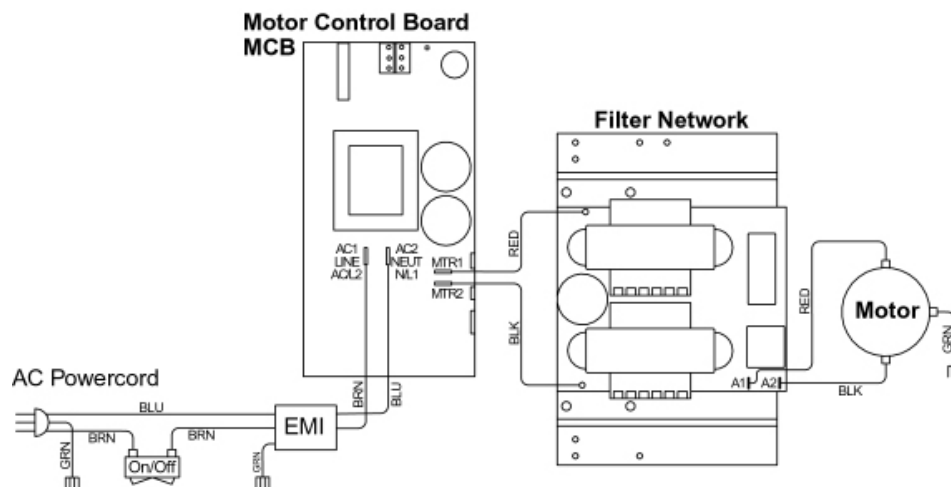

Remove the 2 smaller red and black wires from the A1 and A2 terminals on the Filter Network black (or white and black for 220v units). Install the drive motor wires directly onto the MCB where you removed the Filter Network wires. Plug the treadmill into the wall and continue troubleshooting.

